



YOUR POLYMER SPRING EXPERTS

**Durel - Zellstoffpuffer**  
**Durel - Cellular plastic buffers**  
 BLANCO - Ausführung / design

**NO 16944**

Seite / page 1

mit Innengewinde, Gewindestift und Setzmutter

with internal thread, grub screw and rivet nut

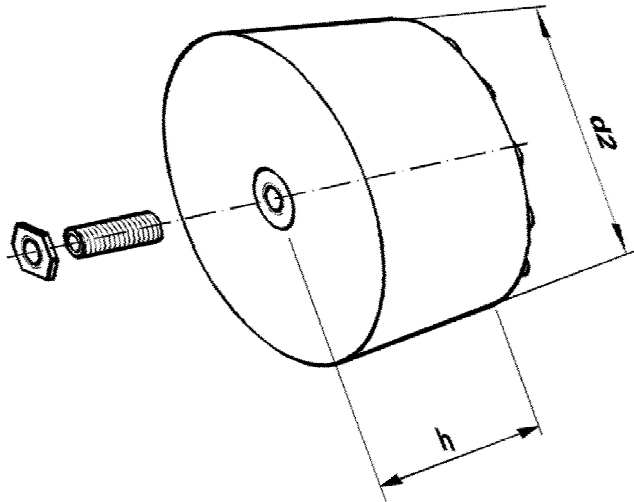

Bezeichnung eines Zellstoffpuffers mit Gewindestift und Setzmutter  
 $d_1 = 160$  .....  
**Durel - Zellstoffpuffer B 160 NO 16944, Ident-Nr.: 96439244**

Designation of a cellular plastic buffer with threaded bolt and rivet nut,  $d_1 = 160$  .....  
**Durel - Cellular plastic buffer B 160 NO 16944, ident-no. 96439244**

Nenngröße size $d_1$	Ident-Nr. identification-no. Ausführung design		Abmessungen - dimensions ( mm )				Arbeitsaufnahme energy capacity kJ <sup>1)</sup>	Federweg compression mm <sup>1)</sup>	Endkraft end force kN <sup>1)</sup>	Stückgewicht unit weight kg
	Durel	B	$d_2$	$d_3$	h	l				
70	10213	964 349 44	65	M 12	66	34	0,25	55	7	0,20
100	10214	964 390 44	95		100		0,8	74	40	0,47
130	10215	964 391 44	122		120		1,6	86	54	0,78
160	10216	964 392 44	155		150		4,2	120	110	1,61
210	10217	964 393 44	200	M 20	200	60	8,0	175	120	3,79

Werkstoffe: Federkörper: geschäumtes Zell-Polyurethan  
 0,50 kg/dm<sup>3</sup>  
 Gewindestift: 45 H - DIN 913  
 Setzmutter: gehärteter Stahl, verzinkt

Material: Spring body: foamed cell polyurethan  
 0,50 kg/dm<sup>3</sup>  
 Threaded bolt: 45 H - DIN 913  
 Rivet Nut: hardened steel, galvanized

1) Diese Werte gelten für Stöße, wie sie beim Kranbetrieb auftreten  
 ( $v = 120$  m/min).

1) These data are valid only for impacts as arise at crane operating  
 ( $v = 120$  m/min).

Durel - Zellstoffpuffer sind für den Einsatz als Federelemente ungeeignet.

Durel - Cellular plastic buffers are unsuitable for the application as spring elements.

Puffer mit Schutz gegen Hydrolysealterung.  
 Temperaturbeständigkeit: -40 bis +80°C

Buffers with increased protection against hydrolysis aging.  
 Temperature stability: -40 up to +80°C

Auswahldiagramme siehe Seite 2.

Diagrams of selection see page 2.

Durel – Zellstoffpuffer  
cellular plastic buffer

70

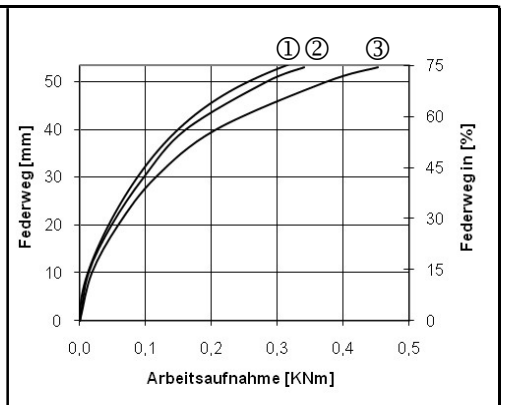
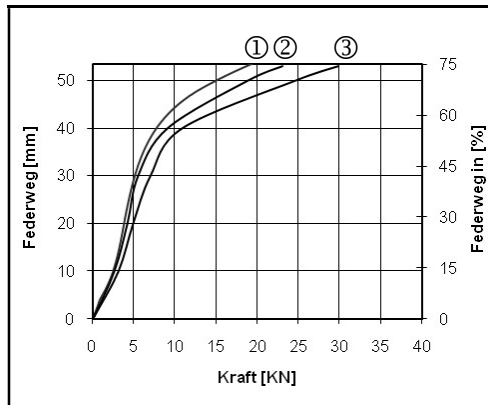

Durel – Zellstoffpuffer  
cellular plastic buffer

100

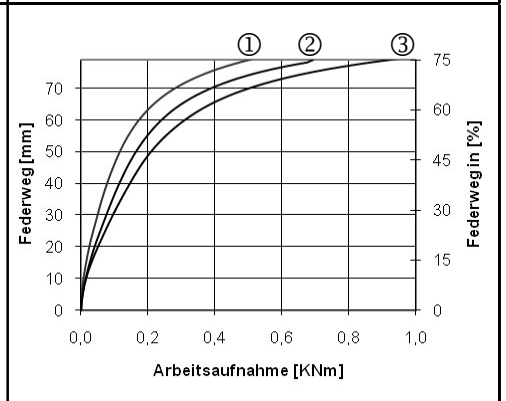
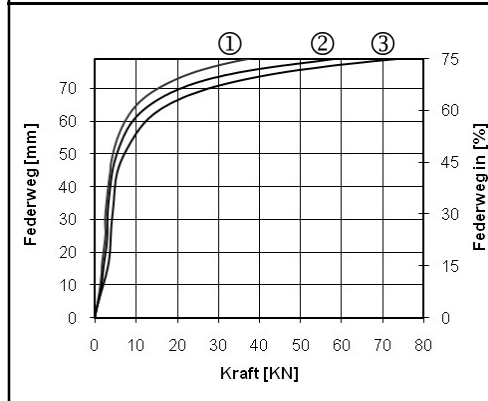

Durel – Zellstoffpuffer  
cellular plastic buffer

130

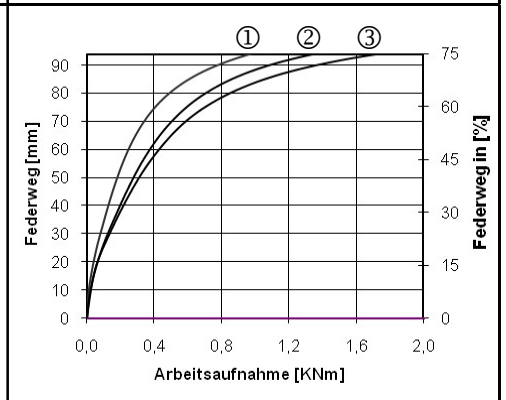
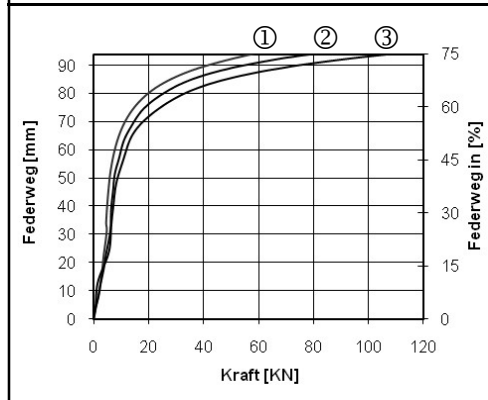

Durel – Zellstoffpuffer  
cellular plastic buffer

160

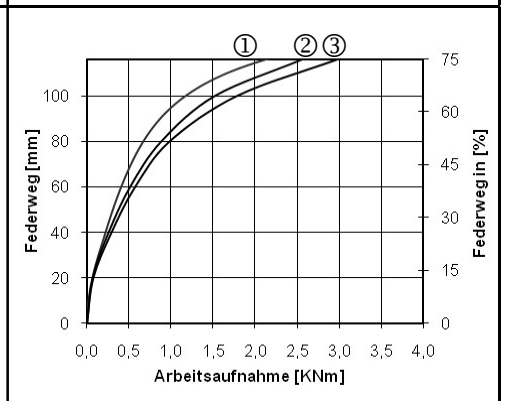
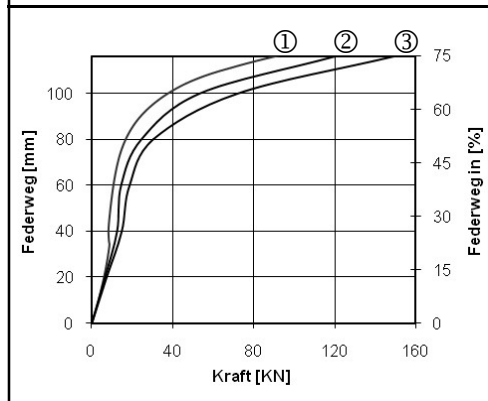

Durel – Zellstoffpuffer  
cellular plastic buffer

210

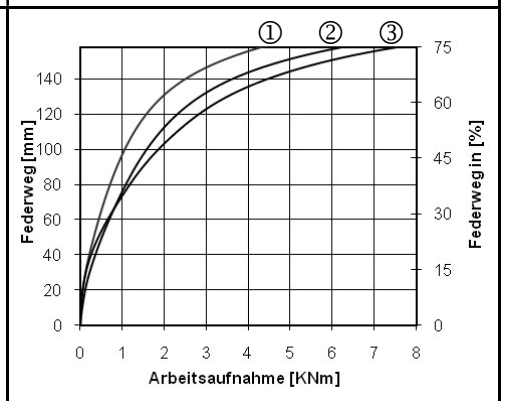
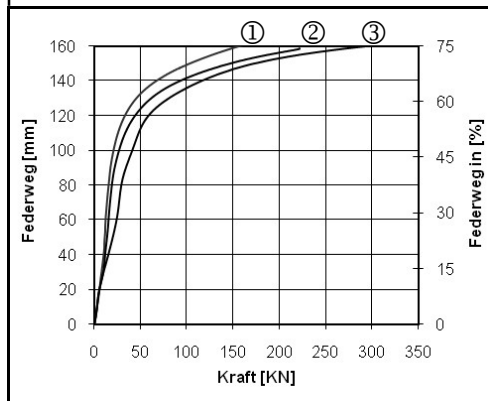

- ① statisch
- ② v = 60 m/min.
- ③ v = 120 m/min.