

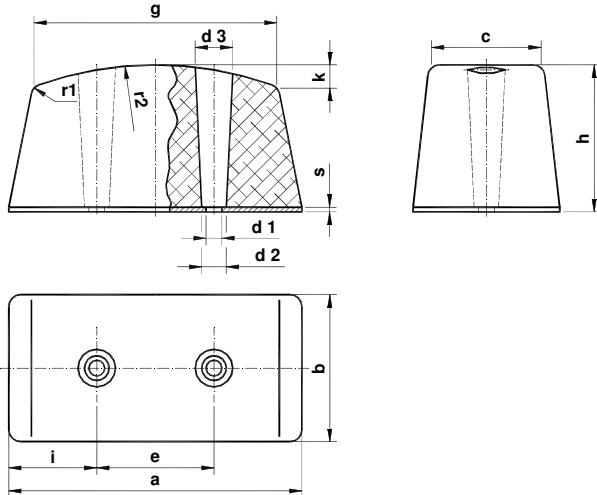

YOUR POLYMER SPRING EXPERTS

Durel - Radpuffer Durel - Wheel buffers

NO 16954



Bezeichnung eines Radpuffers mit einer Kopfbreite c = 80 mm
Durel - Radpuffer 80 NO 16954

Designation of a wheel buffer with head width c = 80 mm
Durel - Wheel buffer 80 NO 16954

Nenngröße size	Abmessungen - dimensions (mm)														Arbeitsaufnahme energy capacity kJ ¹⁾	Federweg compression mm ¹⁾	Endkraft end force kN ¹⁾	Stückgewicht unit weight kg
	c	a	b	d ₁	d ₂	d ₃	e	g	h	i	k	r ₁	r ₂	s				
35	80	40	7	11	15	45	75	45	17.5	5	4	150	3	0.20	20	27	0.2	
45	150	60	11.5	18	24	70	134	59	40	9	5	240	4	0.50	30	75	0.6	
80	200	100	13.5	21	28	90	168	100	55	12	10	300	4	1.80	50	130	2.4	
100	250	125	13.5	21	32	100	212	125	75	20	10	300	4	3.00	60	190	4.9	

Werkstoffe: Federkörper: Gummi mit 70° shore-A
Grundplatte: S235JRG2

Materials: Spring body: Rubber with 70° shore-A
Base plate: S235JRG2

1) Diese Werte gelten für Stöße, wie sie beim Kranbetrieb auftreten.
Radpuffer sind für den Einsatz als Federelemente ungeeignet.

1) These data are valid for impacts as arise at crane operating.
Wheel buffers are unsuitable for the application as spring elements.

